

EBJ
Underwater Junction Box

Function:

Submersible conduit mounted junction boxes for underwater connections.

Specification:

Construction shall be cast bronze and equipped with neoprene cover gasket, stainless steel fasteners and internal ground connection.

Options: (Add suffix)

J - junction box sealant (12 oz)

Note:

- 1-Use only with brass conduit stub ups (see EPA).
- 2-Use with brass compression cord seals (see EGS cord seals).
- 3-Seal junction box with junction box sealant (U.S. only).
- 4-CSA and UL listed.

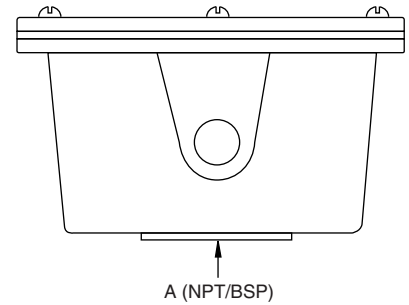
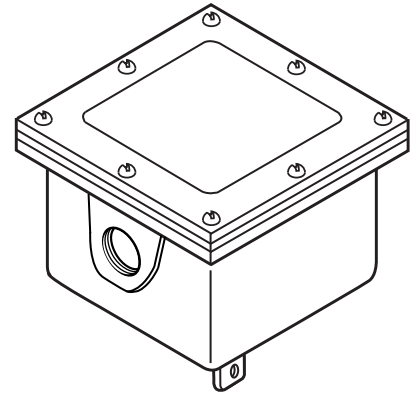

Dimensions

DEFO no.	inside cu. dim.	max. no. side outlets (npt/bsp)	a (npt) (bsp)	length dim.	width dim.	depth dim.
EBJ-202	11"	2	3/4"	4"	3 1/4"	3 1/4"
EBJ-204	22 1/2"	4	3/4"	4 1/2"	4 1/2"	3 3/4"
EBJ-208	40 3/4"	8	1"	5 1/2"	5 1/2"	3 1/2"
EBJ-212	65"	12	1 1/4"	5 1/2"	5 1/2"	4 1/2"
EBJ-216	137"	16	1 1/2"	7"	7"	5 1/2"
EBJ-220	170"	20	2"	8"	8"	5 1/2"

01/01/00