

Function

A multi-purpose spray jet that can be used in small and medium-sized fountains. The jet can also be cast into spray aprons in public playgrounds to ensure vandal resistant installation. Gentle spray coverage.

Not water level dependent.

Specification

Construction shall be machined cast bronze. Face plate shall be removable for easy cleaning with a security key. Ground lug shall be copper with stainless steel fastener.

Water connection: 2" n.p.t. female

Options

W - winter cover

ASL200 - swivel connection, 5° adjustment

ASU200 - swivel connection, 15° adjustment

WMF082 - security key (cover removal)

B.S.P. threading

Notes

1. Requires fine screening at pump for optimum effect (maximum 0.030").
2. Contact Crystal Fountains for customized hole patterns.

Performance

20 ft/s in shaded area

DEFO no.	spray height	3'	5'	10'
NLG200	gpm	30	39	58
	head	5'	8'	18'
	spread	48"	72"	132"
NLG201	gpm	26	34	50
	head	5'	8'	16'
	spread	29"	50"	96"
NLG202	gpm	25	32	47
	head	5'	8'	17'
	spread	36"	53"	94"
NLG203	gpm	26	34	48
	head	5'	8'	15'
	spread	54"	80"	132"

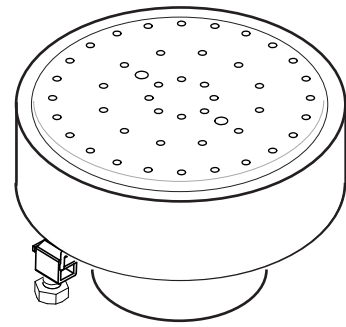

spray patterns and angles

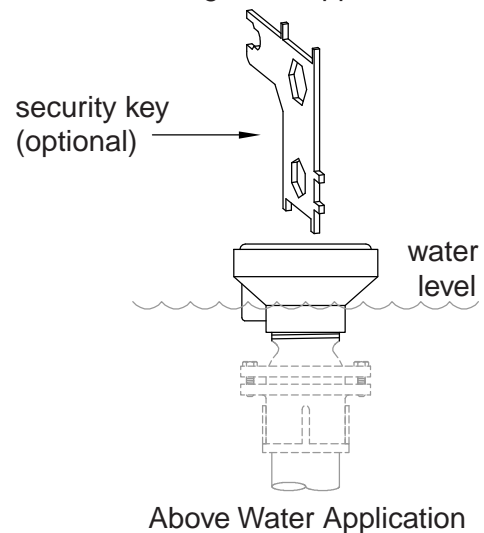
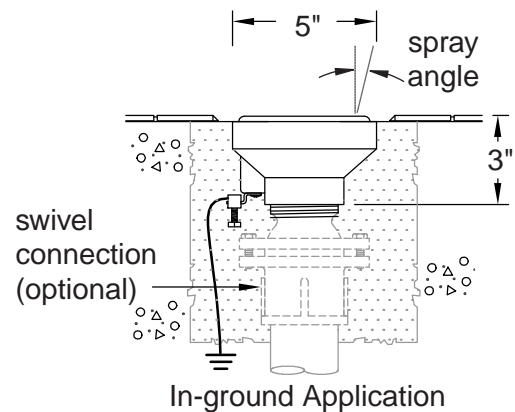
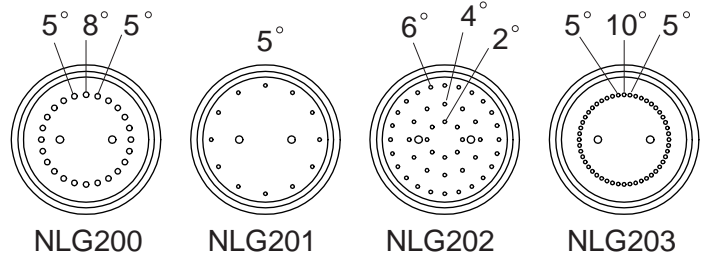

PROPRIETARY AND CONFIDENTIAL

THE INFORMATION CONTAINED IN THIS DRAWING IS THE SOLE PROPERTY OF CRYSTAL FOUNTAINS. ANY REPRODUCTION IN PART OR AS A WHOLE WITHOUT THE WRITTEN PERMISSION OF CRYSTAL FOUNTAINS IS PROHIBITED.

SHOP DRAWING
NLG-D101

www.crystalfountains.com

Crystal Fountains

GROUND JET

SERIES
NLG

REV.
C

TEL. (905) 660-6674

FAX. (905) 660-6916

5.15.2004